

Part A

HCD PROJECT

Design with empathy

Principles of good design

- innovative
- useful
- aesthetic
- accessible
- enduring
- sustainable

Dieter Rams
10 principles?

- o economic
- o social
- o cultural
- o aesthetic
- o technical

Notes on the 4 Pleasure framework

- socio-pleasure — social interaction
- physio-pleasure — the feel of using things, places
- psycho-pleasure — cognitive (understanding) and emotional (liking, disliking) experience of using things, places
- ideo-pleasure — values and beliefs

Other questions

- o What do you look forward to?
- o How would you like to improve your circumstances?
- o What do you like about this stage of life?

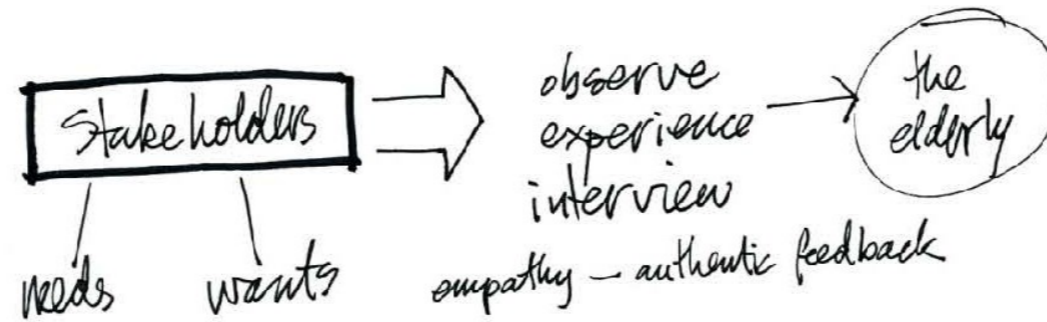

- ### Questions
- o Who do I know that is elderly?
 - Grandmother x2
 - Grandfather x1
 - neighbour
 - people in the retirement home.

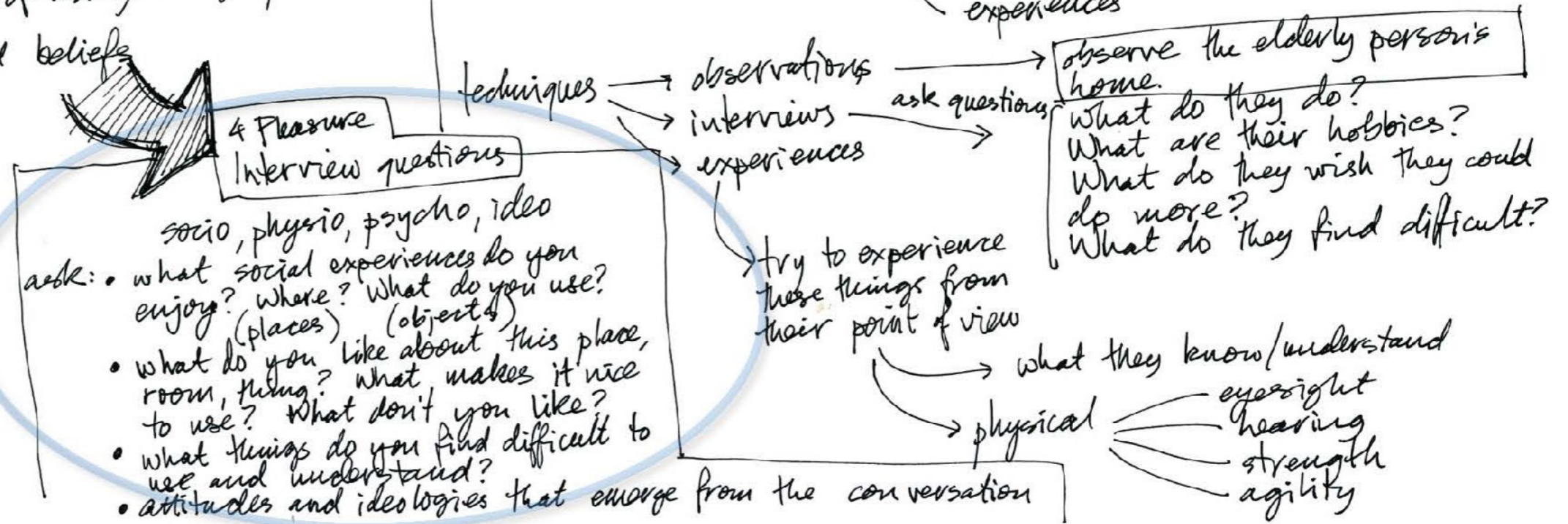
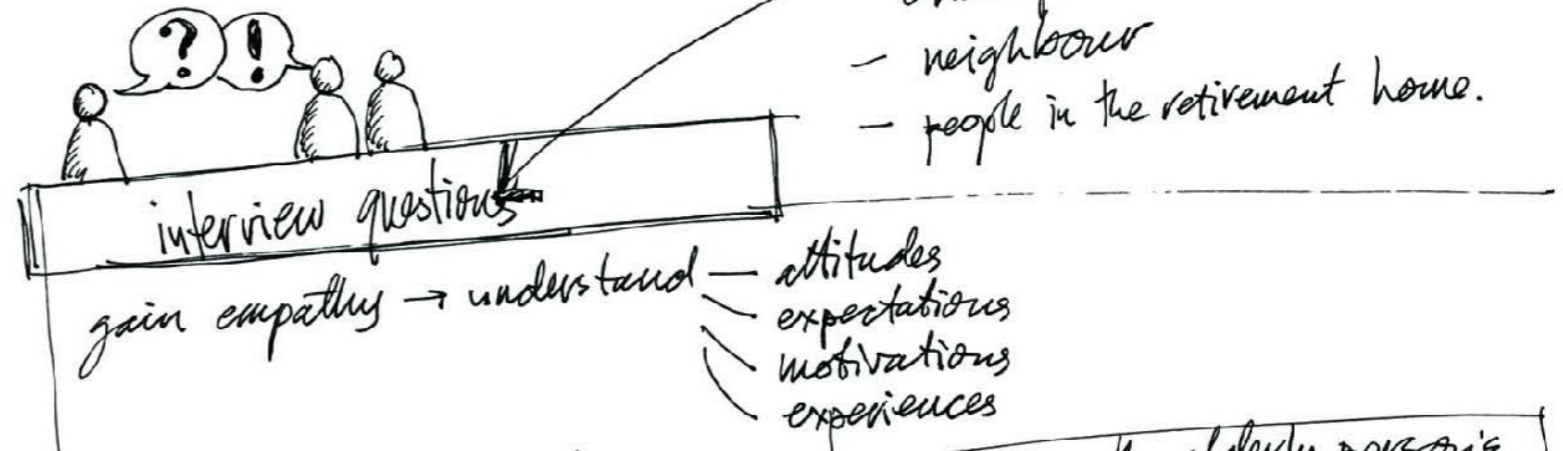

My Grandparents' House

Occasional Table



From Ikea.

Occasional table folded up



opened for 2 (Gran and Pop) but can open out for 6 if necessary (but not much room for that)



padded chair

useful storage drawers

Spare bedroom



spare bed

sewing machine

clothes to be donated



wardrobe full of clothes



iPad) charging
iPhone)

power from ensuite

clock radio instead of smartphone



Emergency Alarm



Alert button next to bed



lanyard holder can be unclipped

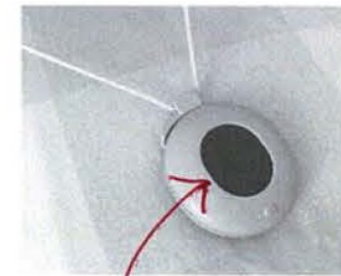

alarm button

Alarm pendant - may be worn or hung in a good place

Stakeholder Interview

Interview with Allen & Lilly (grandparents)

Location: home, high set weatherboard house
 7 km from Brisbane 2 people/residents
 large yard - chooks!
 1 car, nearby bus service (prefer car)

Looking forward to:

- school holiday visit of daughter (teacher)
- visit of Lilly's brother (uncle - he likes doing handy man things around the house)
- stay in the spare room/visitors room
- bowls during the week
- gardening → harvesting veggies → planting for spring
- State-of-Origin - need to fix TV antenna - got a new big TV!

What do you like about life?

- Time! Time to see friends, work in the garden, family
- Choice. We could travel if we wished to
- Grand children - spoiling them, watching them grow up

Ideas • guest room interior - storage and also attractive accommodation

- easy-to-use TV & remote control
- digital security?
- video chat - long distance socialisation
- home security - feel safe but not locked in
- gardening tools, apron?

Ideas that help people like Allen & Lilly not necessarily just for Allen & Lilly.

not my client

Observations

Home - 3 bedrooms

- master bedroom - 2 beds
- visitors room
- utility room - sewing machine, bed, clothes boxes

Living room

- old, small TV
- DVD player } old!

Kitchen

- CD player/radio
- new fridge
- modern electric stove
- kitchen table
- no dishwasher
- no microwave

- router WiFi

Verandah - enclosed sitting room

Smell - a little musty, warm, home

worried about security → cooking, baking theft home invasion

Observation: safety is really important - influences much behaviour

ideo-pleasure
 security
 fear
 change

ideo-pleasure?
 self sufficiency

psycho-pleasure

worried about how hard they are to use

"why do they have to be 'smart'?"
 ↓
 just wants a simple TV.

Contact & communication → social is important to them

Lilly's smart phone → Mainly phone - land line cordless phone

Samsung Galaxy - "Words With Friends" game used for social messaging.

Prefers to talk on the phone rather than text. → like Scrabble. keeps the mind sharp.

socio- and psycho-pleasure

How would you like to improve your life, circumstances?

- New TV
- Improve home security - not feeling locked in but safer
- Sort out the third bedroom - tidy up, store stuff elsewhere → be able to have more guests
- Better contact with distant friends and relatives → widen social experience
- Digital security - worried about scams, hacking

Empathy

Project Ideas

Which of these ideas will lead to a product, service or experience environment that will help make old age attractive, pleasant and interesting?

Guest room interior

storage system to tidy up room (allow use as a guest room) → bed with storage underneath

bed - double or single?



Easy TV & remote control

Large flat screen TV with simplified remote control — plus DVD player?

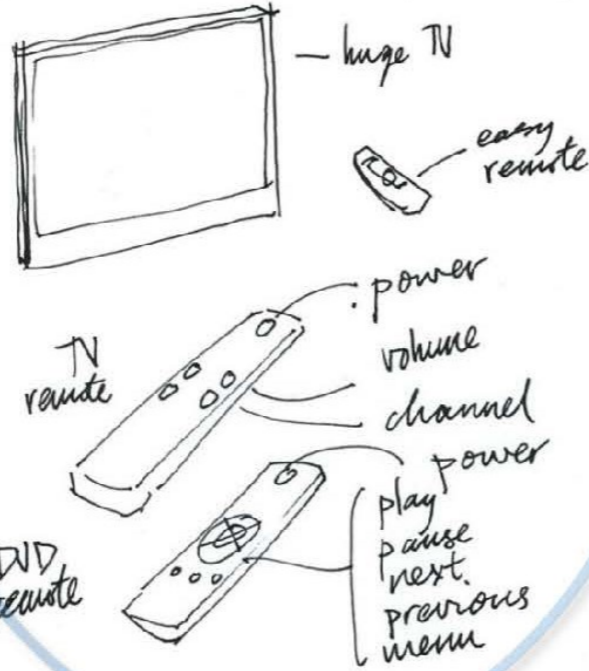

Home security

Alarm system
CCTV monitoring
Door lock/video monitor of callers.

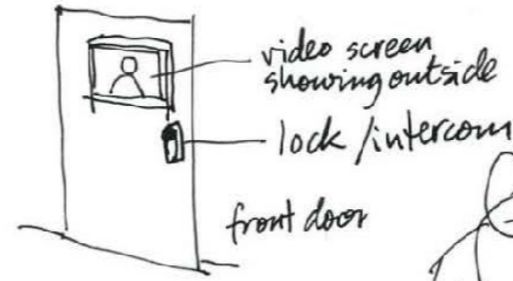

Personal alarm (carry around home)
security - lets you access the house without setting off alarm

Social communication

long distance - chat (voice)
chat (video)

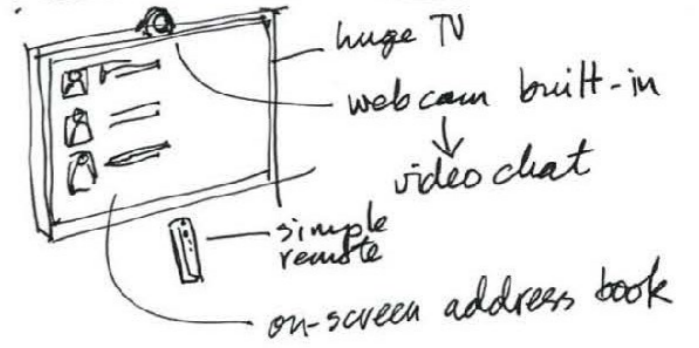

Gardening

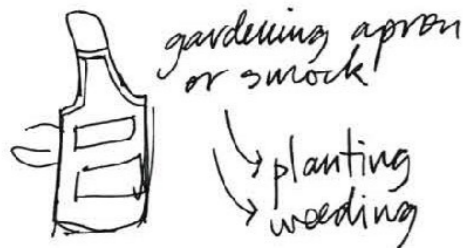

attractive to elderly people
not so attractive enough to be seen wearing by visitors, neighbours

male version
masculine style

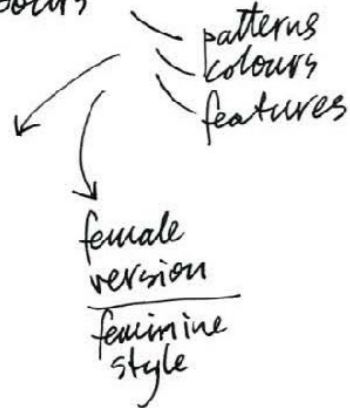

Social kitchen

the ideal kitchen for cooking and entertaining family and friends

- recipe books
- shopping list
- cooking
 - sink
 - fridge
 - stove
 - oven
 - pantry
 - bin
 - dishwasher



how many people?

decor? style?

- eating
 - table
 - chairs
 - family photos

Feedback sheet: <u>STAKEHOLDERS, ALLEN AND LILLY.</u>	
Project Ideas	Which of these project ideas would you like me to develop?
	Please place a tick along the line that best describes your need or want
GUEST ROOM INTERIOR	Immediate need.....would be nice one day ✓
TV AND REMOTE	Immediate need.....would be nice one day ✓
HOME SECURITY	Immediate need.....would be nice one day ✓
SOCIAL COMMUNICATION	Immediate need.....would be nice one day ✓
GARDENING	Immediate need.....would be nice one day ✓
SOCIAL KITCHEN	Immediate need.....would be nice one day ✓

Part B

Design brief

The main constraint of this project was to use design to make the experience of ageing seem more attractive. The focus had to be on people over 60 years old. I identified my grandparents (Allen and Lilly) as older people who I could help. I interviewed and observed them, and identified six different needs and wants. The problem that I have selected was identified by my grandfather. He mentioned their interest in watching sport and movies on TV and DVD. Their TV is old and they would like to update it, but are frustrated by current televisions and DVD players. New TVs are complicated to use and have a large range of features and controls. This includes the remote controls and the function screens on the TV. Additionally, the terminology used is unfamiliar and confusing. My grandmother prefers to leave this to my grandfather, but even he finds it puzzling.

I have decided to design an easy TV that will suit an older user like my grandparents. The design should focus on improving the enjoyment of the TV by older people. I will do this by considering both their physio-pleasure and psycho-pleasure. The problem is defined by the technical features, but the aesthetics of the TV and controls must also be considered.

Design criteria

Must:

- make the TV, DVD and remote control physically easier to use (useful)
- be elegant yet simple in its function to make the TV, DVD and remote control easier to understand (accessible)
- be compatible with the décor and tastes of older people (aesthetic).

Should:

- include aspects that are new or unique compared to commonly available TV and DVDs (innovative).

Must not:

- be patronising to older people or have limited appeal to a very small number of users (sustainable).

TV INTERFACE



LG TV
top level menu



channel list



Setup Menu
- hardly ever used
- maybe elderly people don't need this?



Audio Menu
- most people never touch this after setting up a new TV



Picture Menu



Time Menu
- Isn't time setting automatic on digital TVs?



Lock
- child lock may be useful for when young grandchildren visit



Options

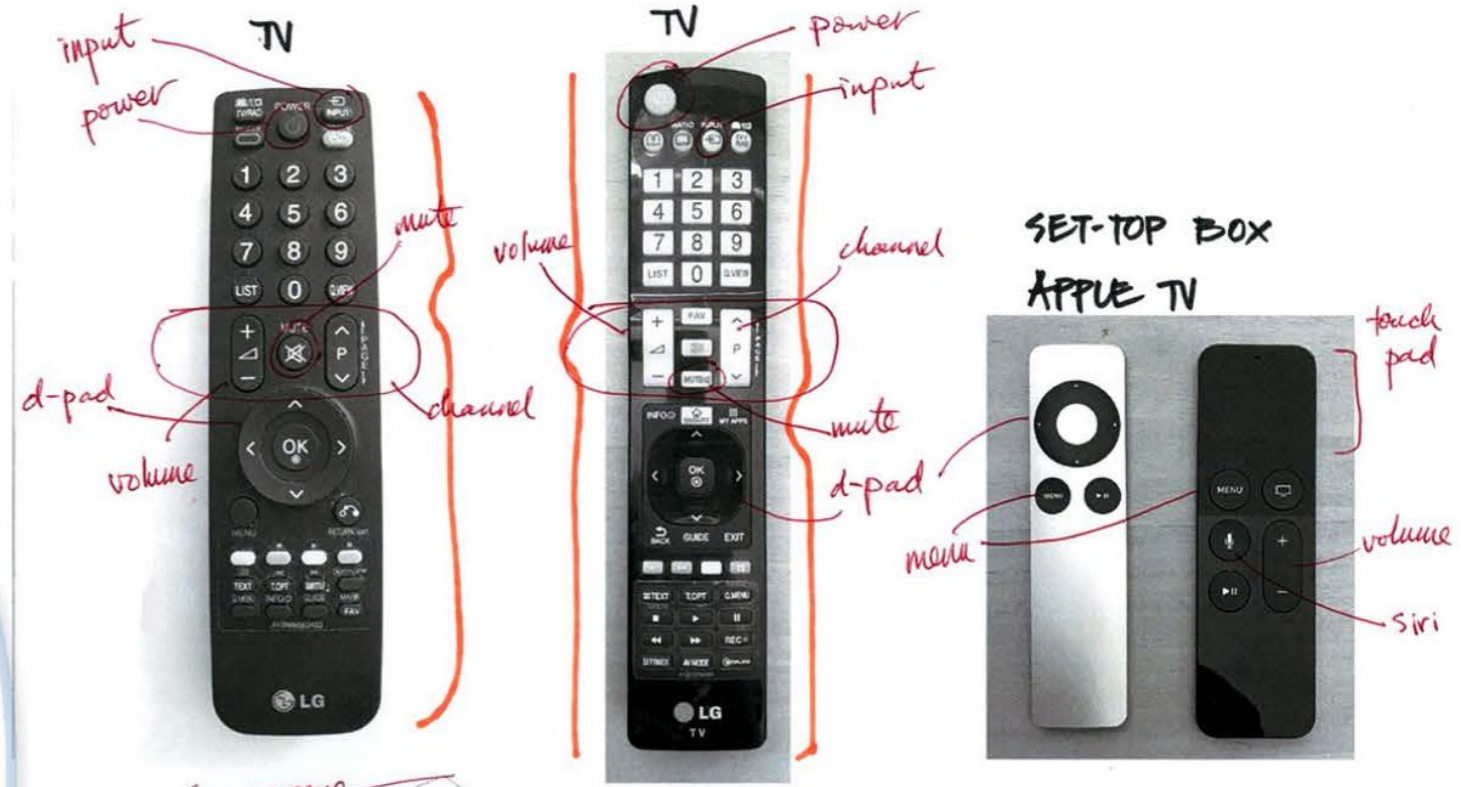

- Most Important Controls
- Power → obvious!
 - Input → DVD, can be confusing
 - Volume
 - Channel } everyone understands these
 - D-pad - useful for menus but old people get confused

Easy TV

A large flat-screen TV with a very simple interface that elderly people can use and enjoy.

- simple remote
- set-up functions that someone else can do for them
- only the most important functions

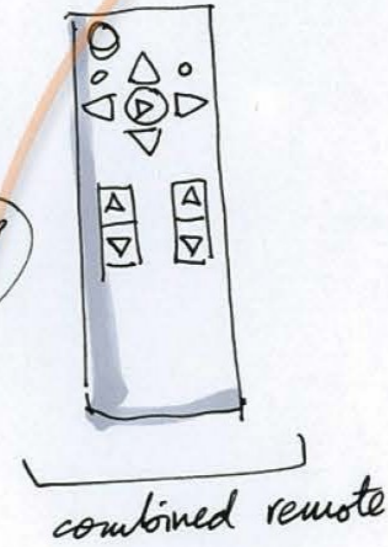
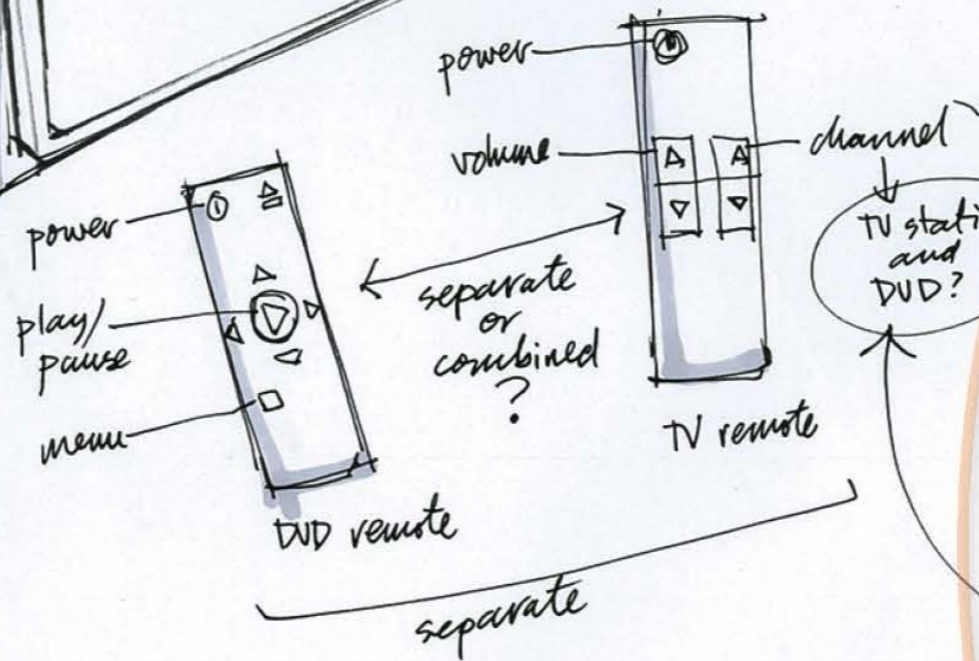
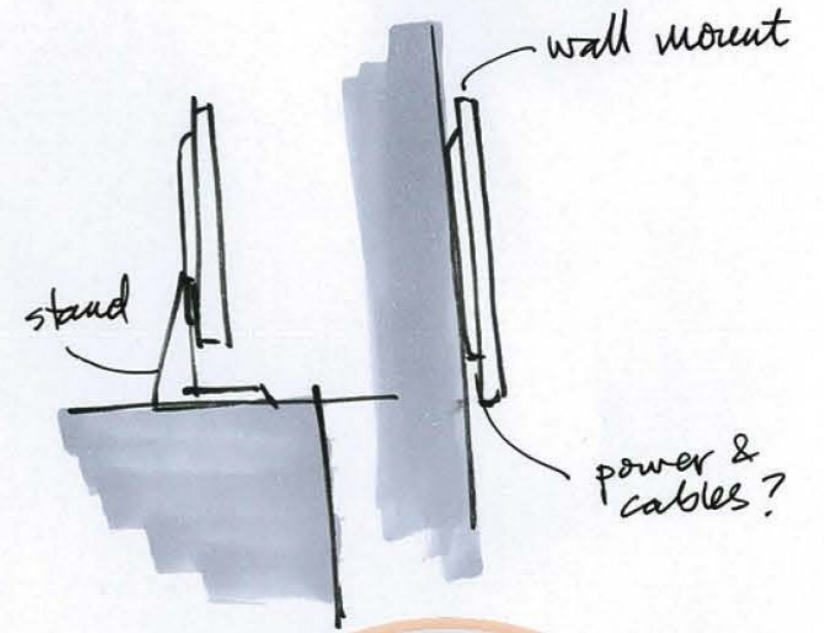
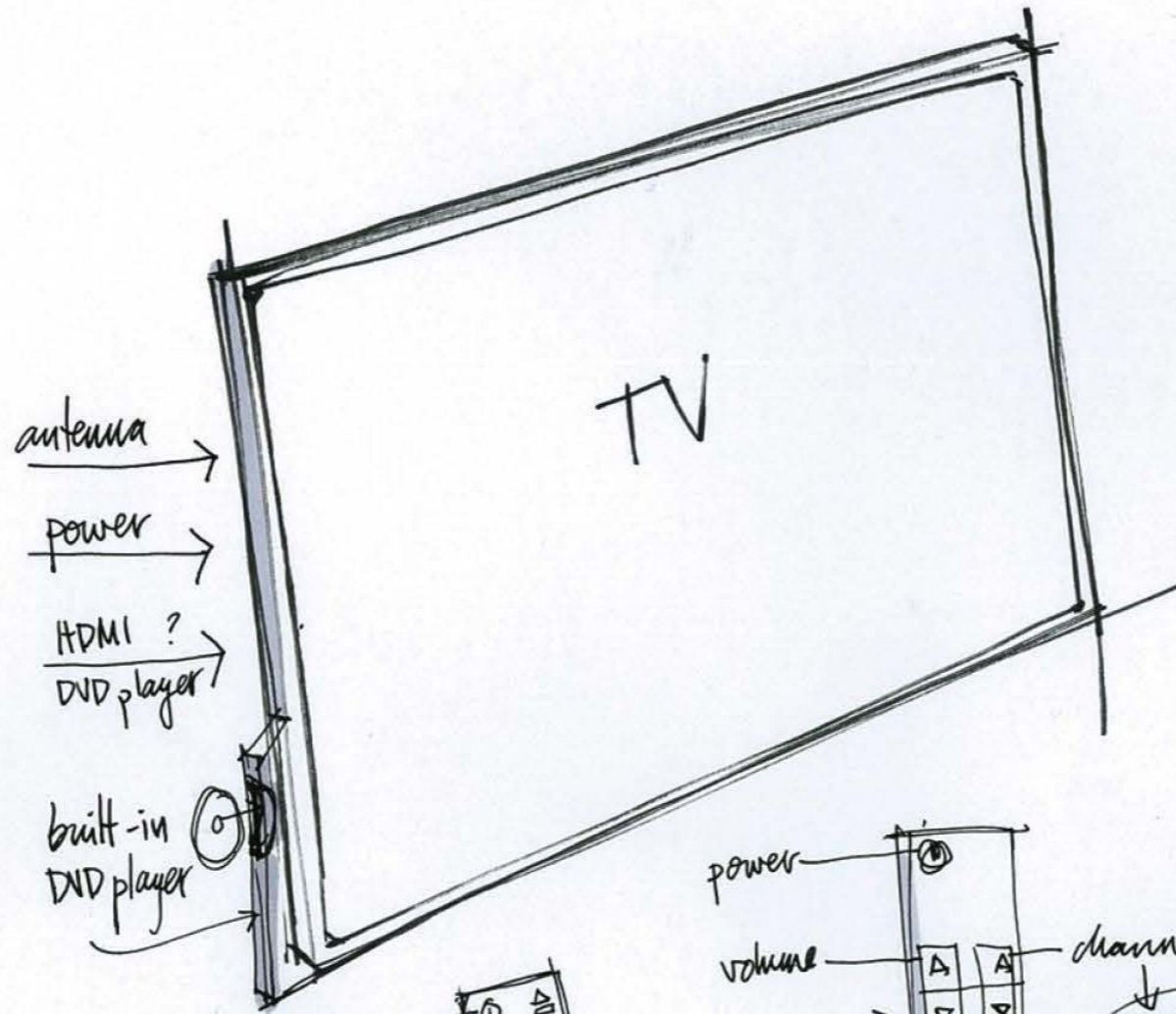

How to make the mode clear
TV DVD
switch easily yet visible

dedicated DVD "channel"?
physical switch?
slider switch

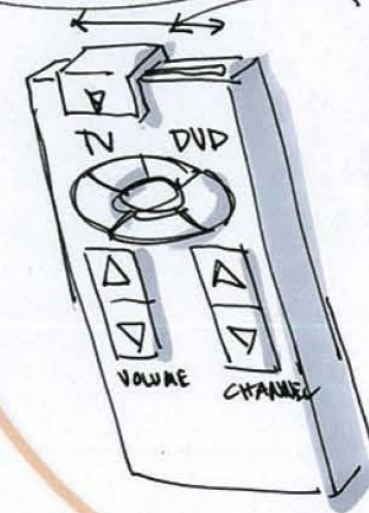

Remote control styles

boxy

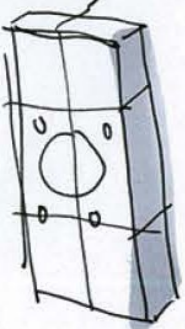

curvy



'ergonomic'

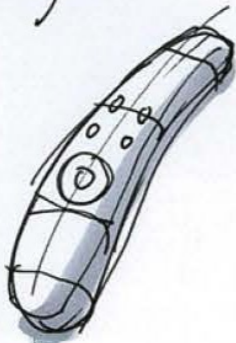

Pros and Cons

Combined
• only 1.
• fast

• more complicated
• confusing?

separate
• simpler
• easy to use

• two remotes to keep track of
• 2x batteries

SIMPLE TV DESIGNS

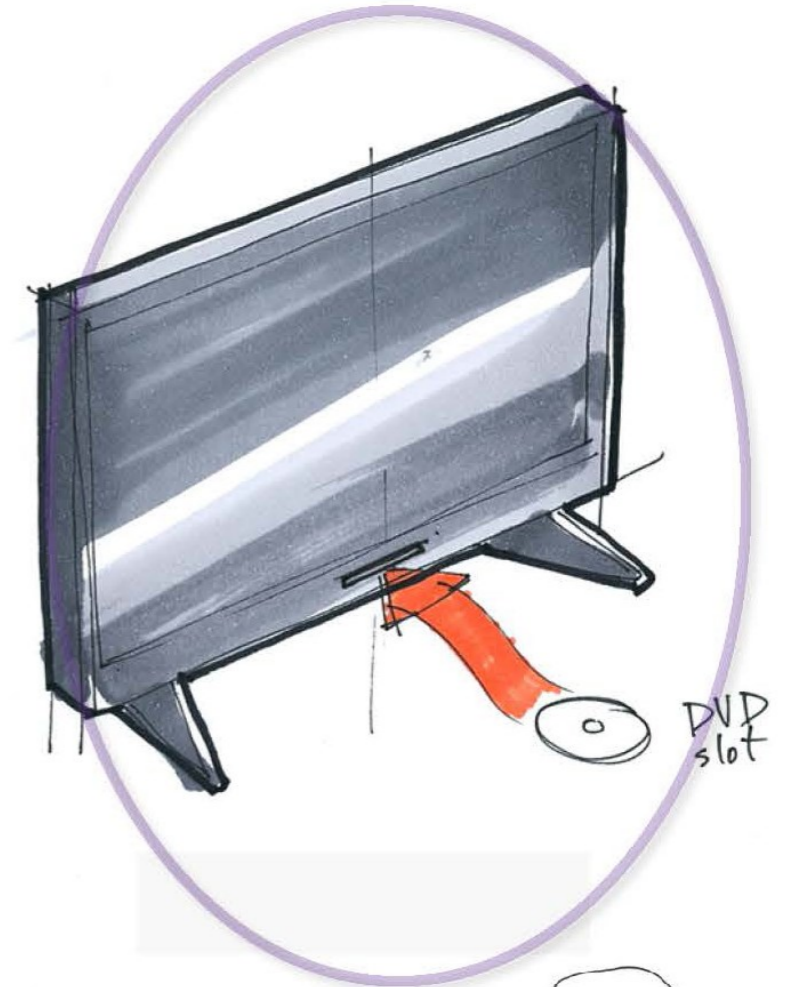
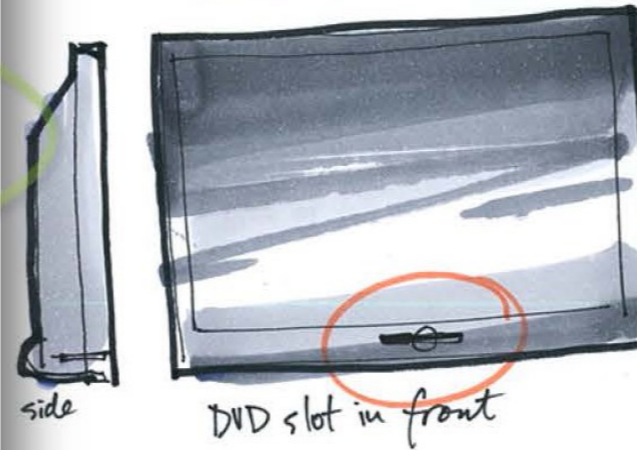
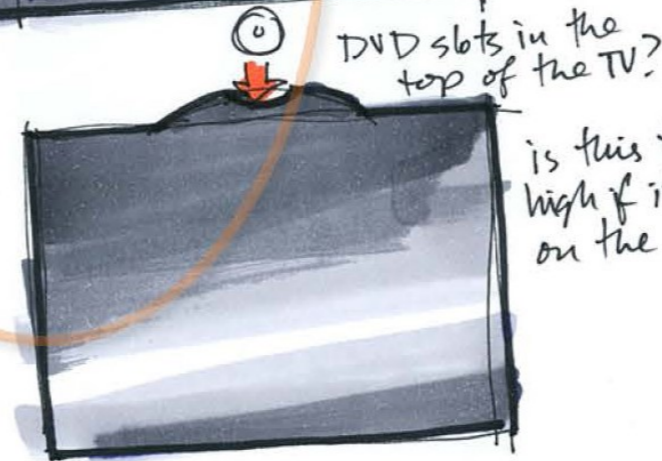
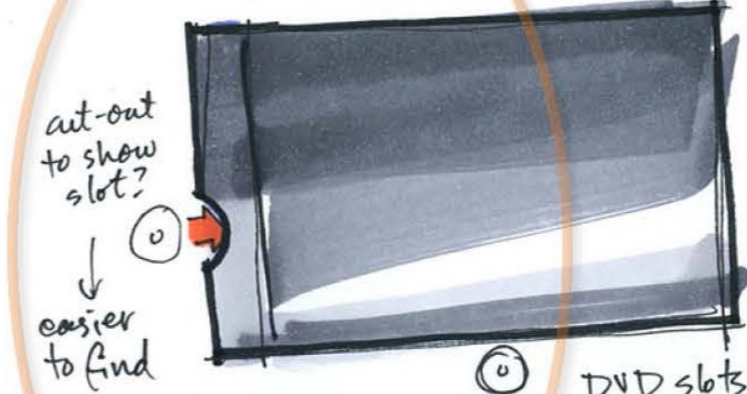
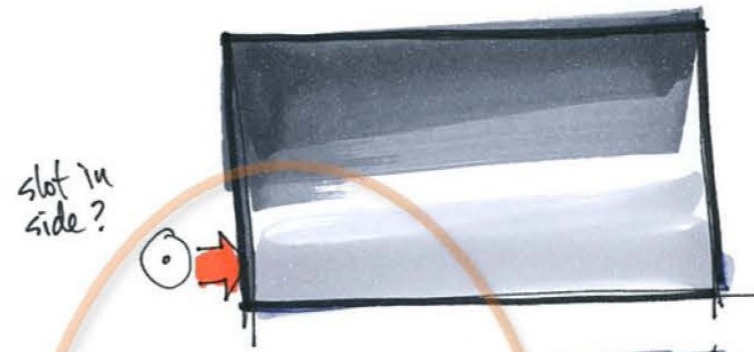
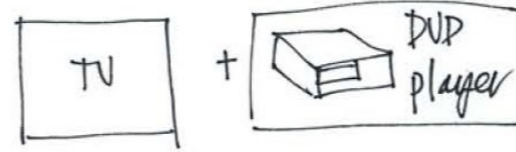
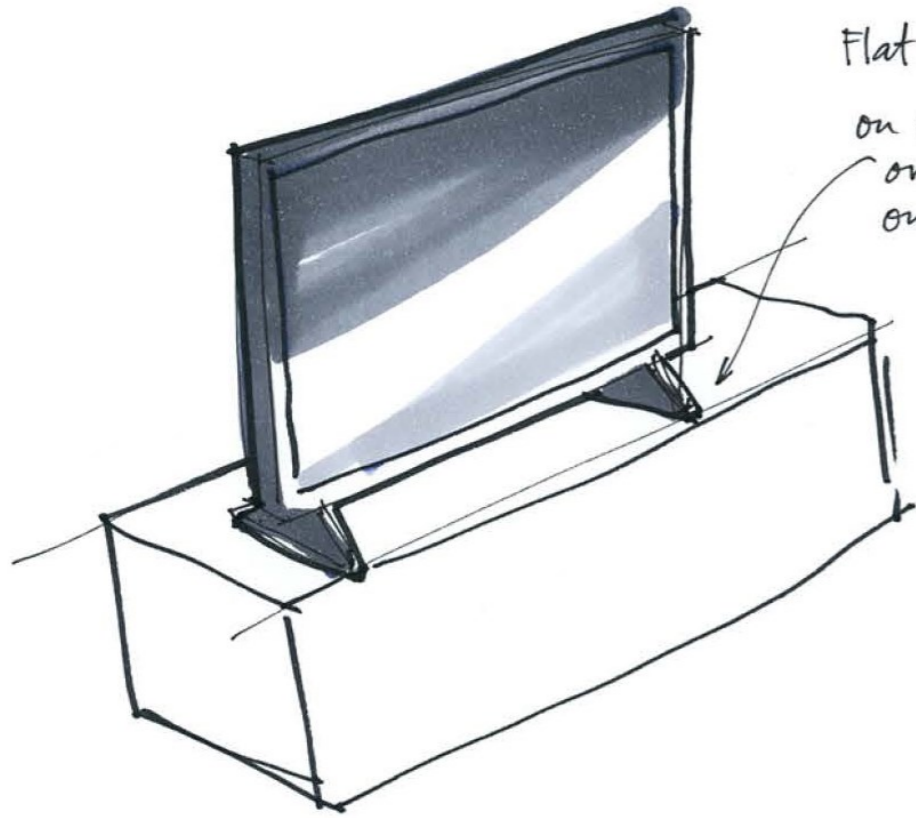

Feedback sheet: SIMPLE TV: Meeting with Allen and Lilly

Design criteria	☹	☺	☺	☺	Attributes to be used in the design concept
Make the TV and DVD physically easy to use				✓	DVD in front. Would the TV be deep enough for this?
Make the use of the TV and DVD easy to understand				✓	Combination of DVD and television DVD in channel menu.
Have a remote control that is easy to hold or use on the arm of a sofa or armchair				?	
Be easy to install and setup, perhaps with the assistance of a more technical user?			✓		No wires to plug in. Sits on shelf. Might not be able to mount on wall. Bedroom?
Make the most common functions easy to access				✓	It is clear where the DVD goes.
Be elegant yet simple in its function				✓	Yes, this is nice.
Be compatible with the décor and interior design tastes of older people					Nice, simple look stand is OK - will sit on TV unit nicely.
Must not have highly technical features that are rarely used			✓		The idea for the input controls is good.
Must not be patronising to older people			✓		Looks like a normal TV

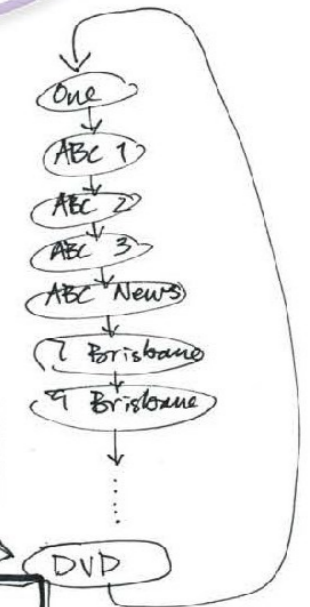

DVD is just another "channel" instead of an input

Same for other inputs, e.g. Foxtel, Apple TV, etc.

slow but easy to understand

- easy to reach
- can light up to show where to put the disc.

Simple TV/DVD Remote concepts, ideas, forms

shapes

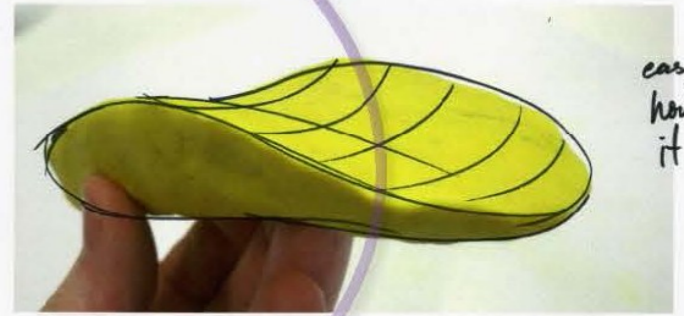
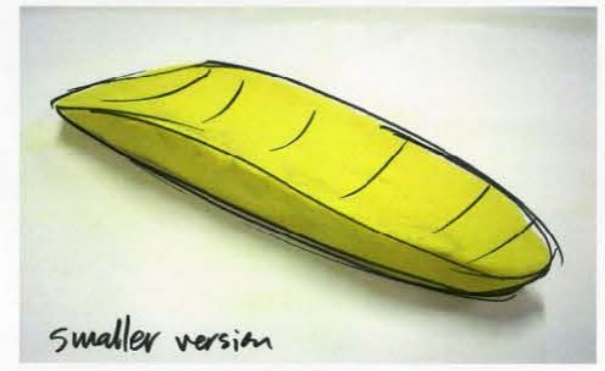
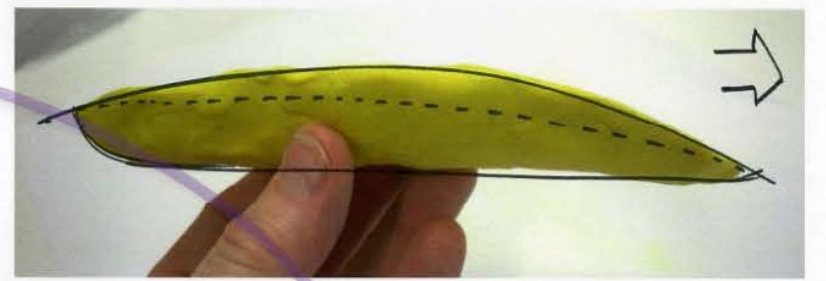
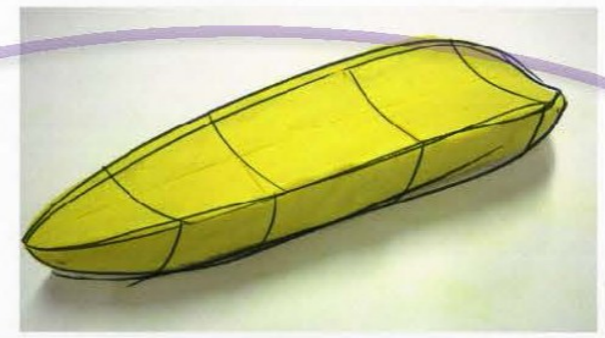
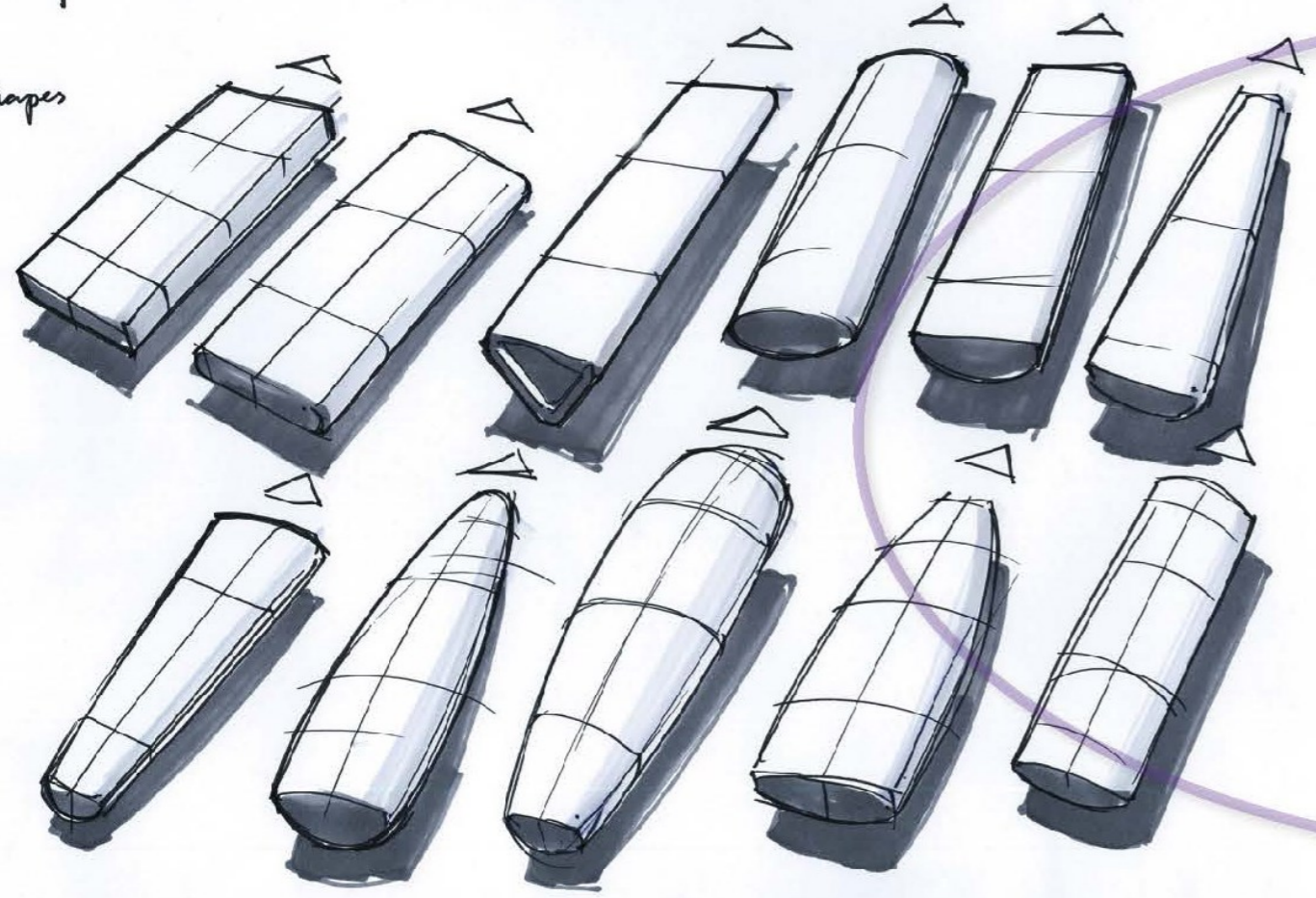

easy to identify how you hold it

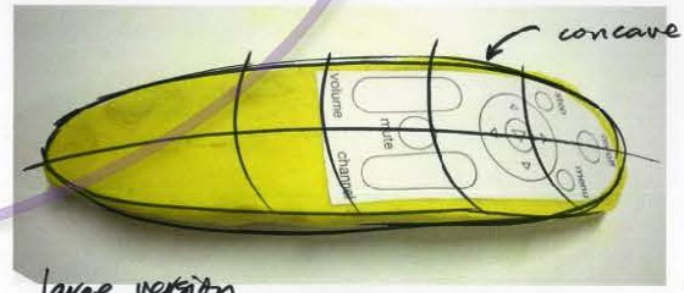

large version



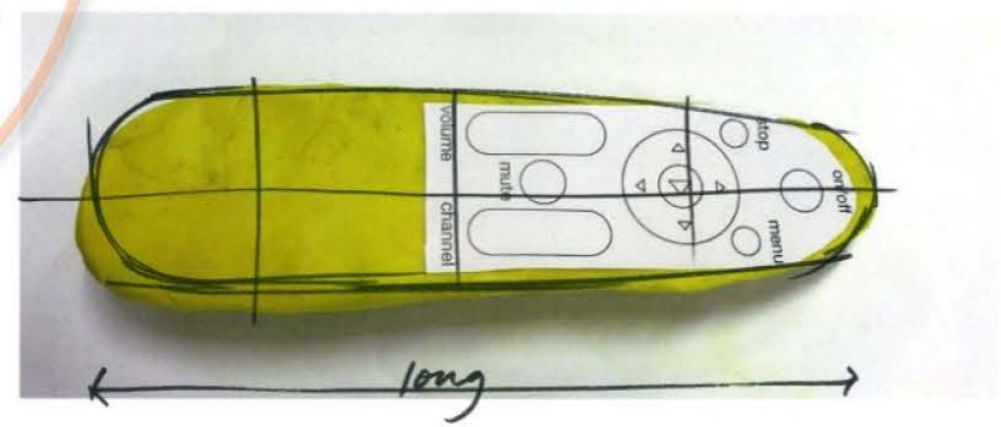
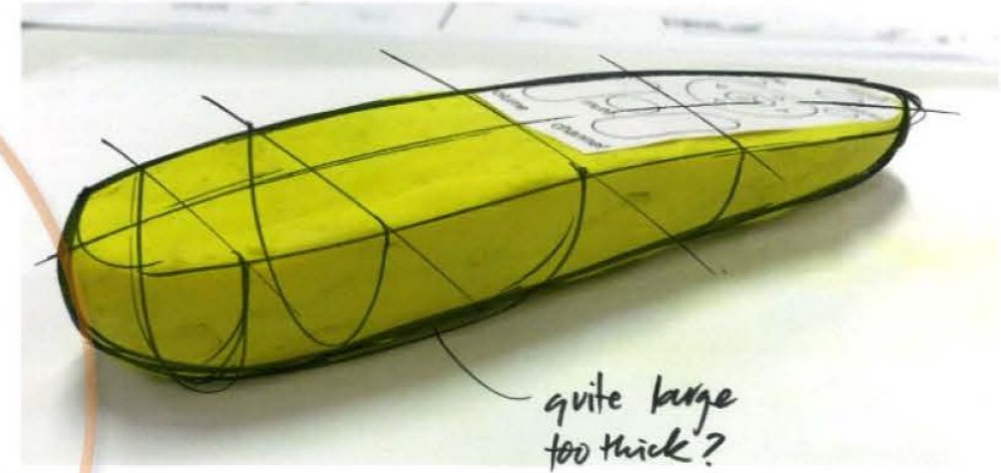
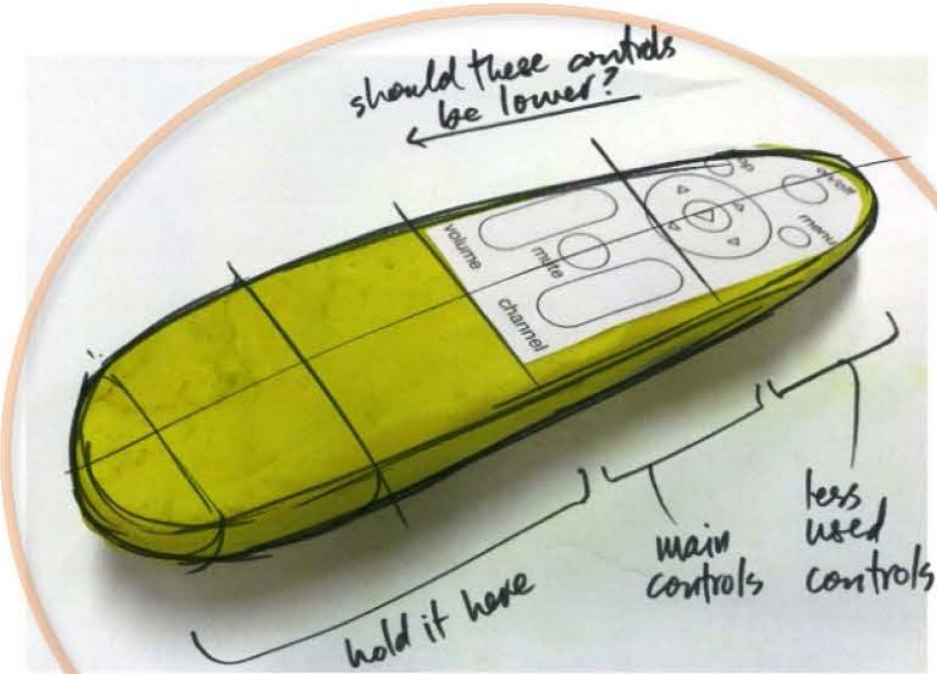





smaller version







Familiar too large? - But hard to lose!

Simple TV/DVD Remote: Buttons

TV

- Power 
- Volume 
 -  increase
 -  decrease
- Mute  
- Channel 
 - up
 - down
- Menu  use this to select DVD mode
- Setup functions 

DVD

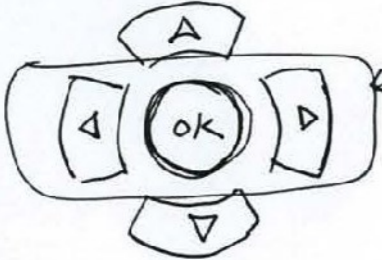
- Play/pause 
- Stop 
- Menu  symbol?
- Next/fast fwd.  combine?
- Previous/rewind  too confusing?
- Navigation d-pad 
 - Enter/select

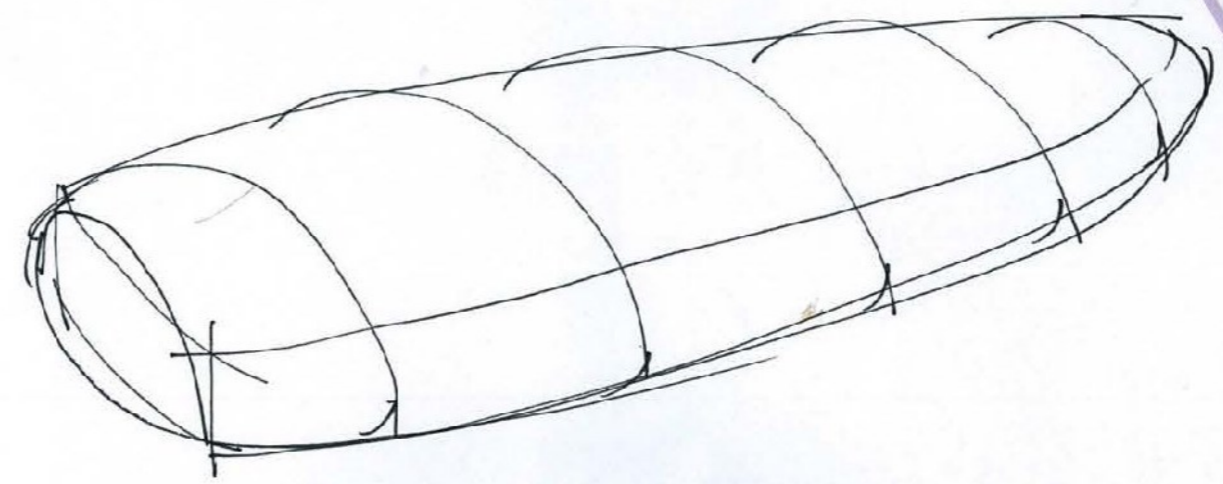
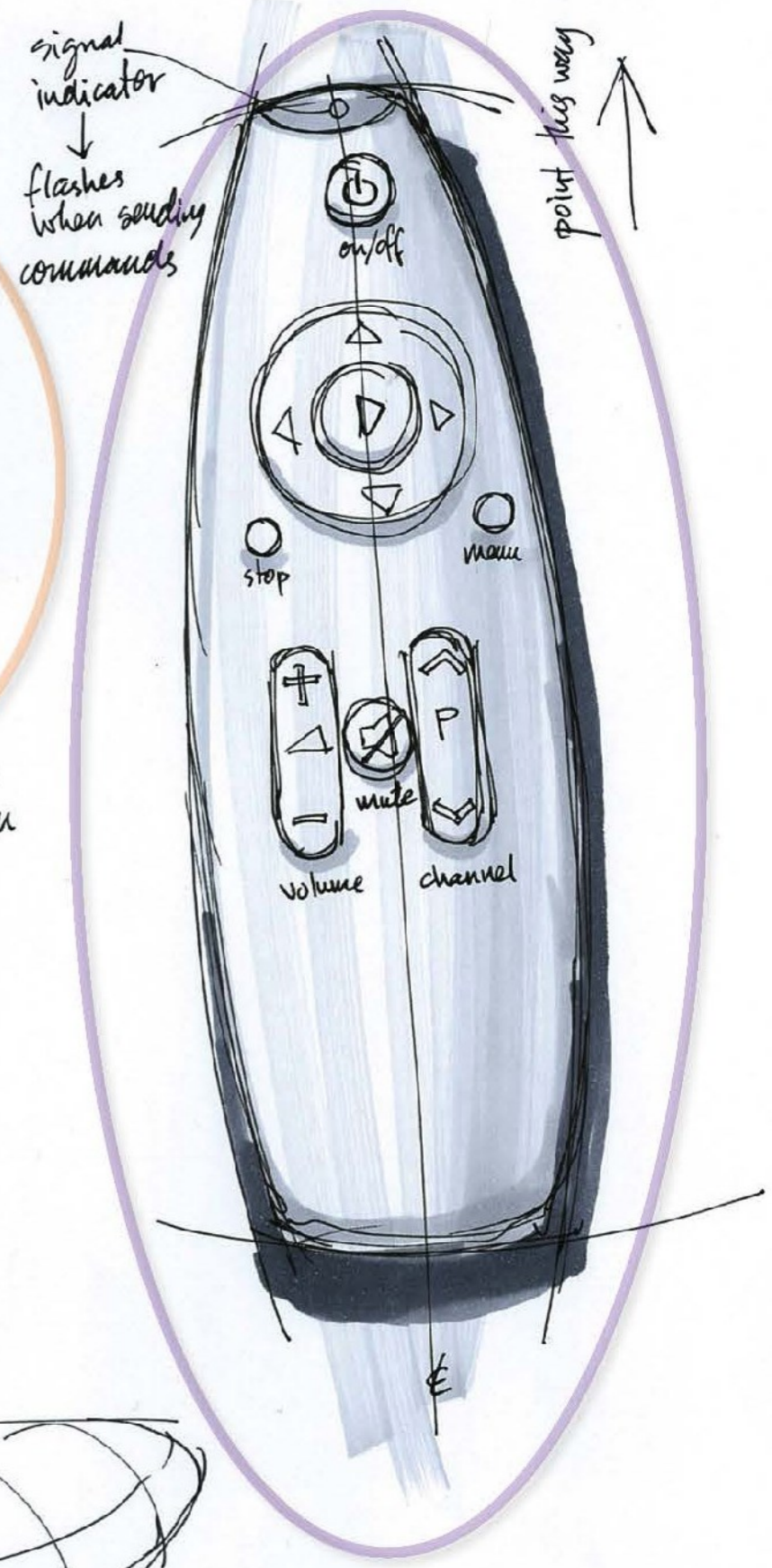
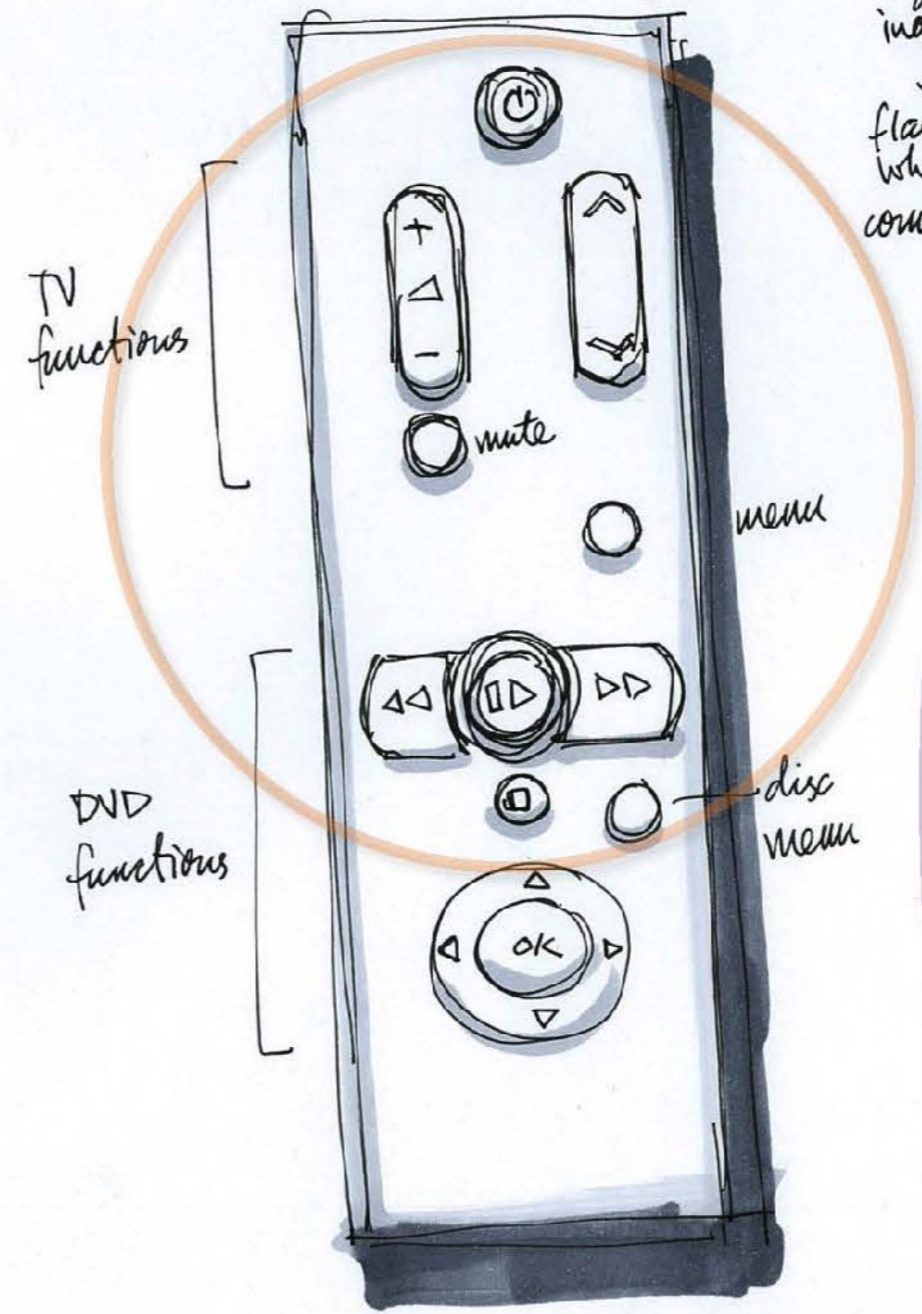

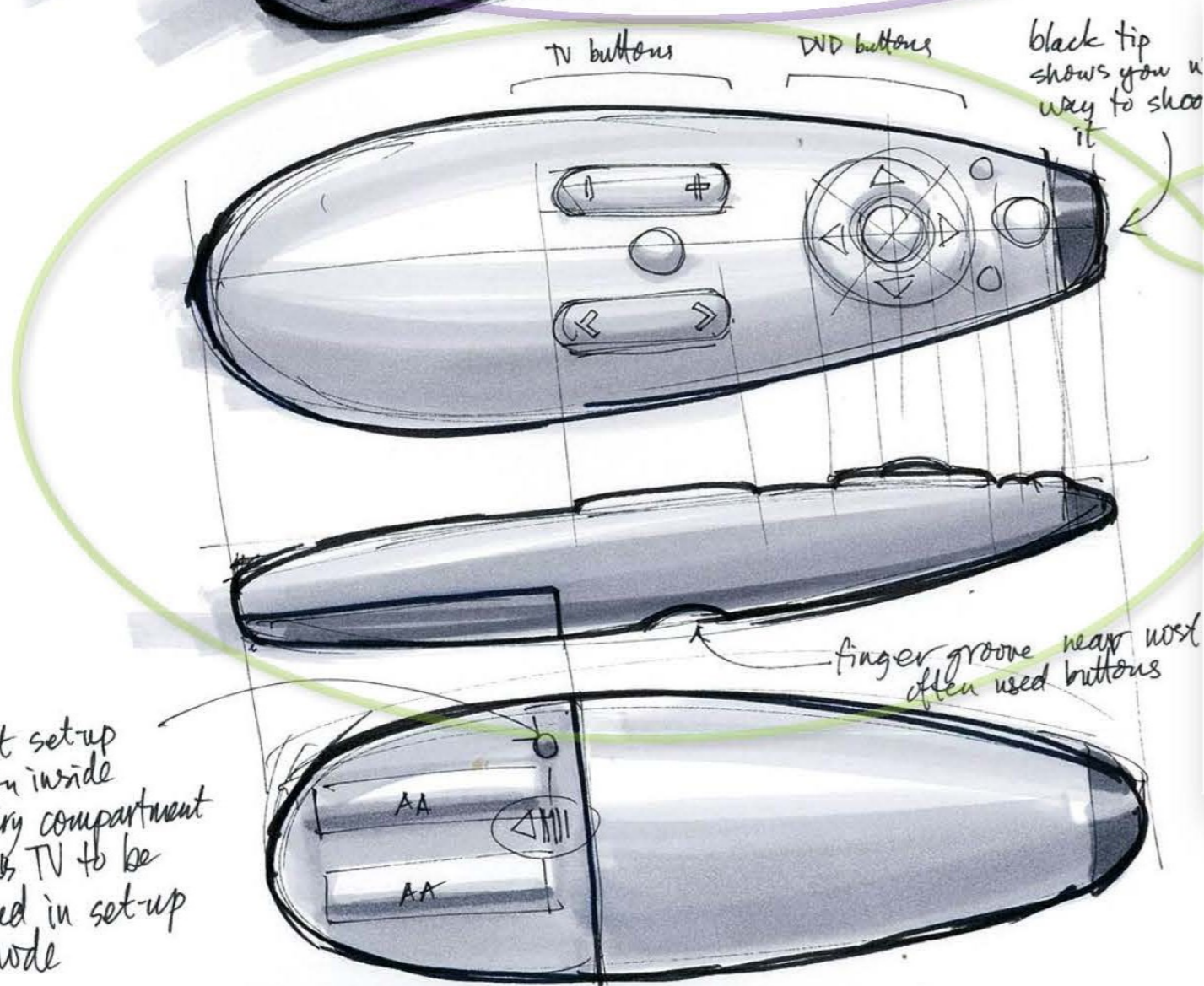

Feedback sheet: Remote Control 1 - Meeting with Allen and Lilly

Design criteria	☹	☺	😊	☺	Attributes to be used in the design concept
Make the TV and DVD physically easy to use		✓			Similar in style from existing remote controls but less complicated. TV buttons.
Make the use of the TV and DVD easy to understand			✓		Could the arrows on the circle be raised? Simple layout of buttons.
Have a remote control that is easy to hold or use on the arm of a sofa or armchair		✓			Curved shape may roll off the arm of the couch. Would it get lost too easily between couch cushions?
Be easy to install and setup, perhaps with the assistance of a more technical user?				✓	The hidden button is a clever idea.
Make the most common functions easy to access			✓		Like the recessed on/off button.
Be elegant yet simple in its function					The shiny black tip - shows which way to point and you can feel which way to hold it. Doesn't particularly appeal.
Be compatible with the décor and interior design tastes of older people					Nice and simple.
Must not have highly technical features that are rarely used			✓		
Must not be patronising to older people			✓		No problem with this but perhaps it could have more information or button labels. Maybe this would make it feel too complicated though.

secret set-up button inside battery compartment allows TV to be placed in set-up mode

finger groove near most often used buttons

black tip shows you a way to shoot it

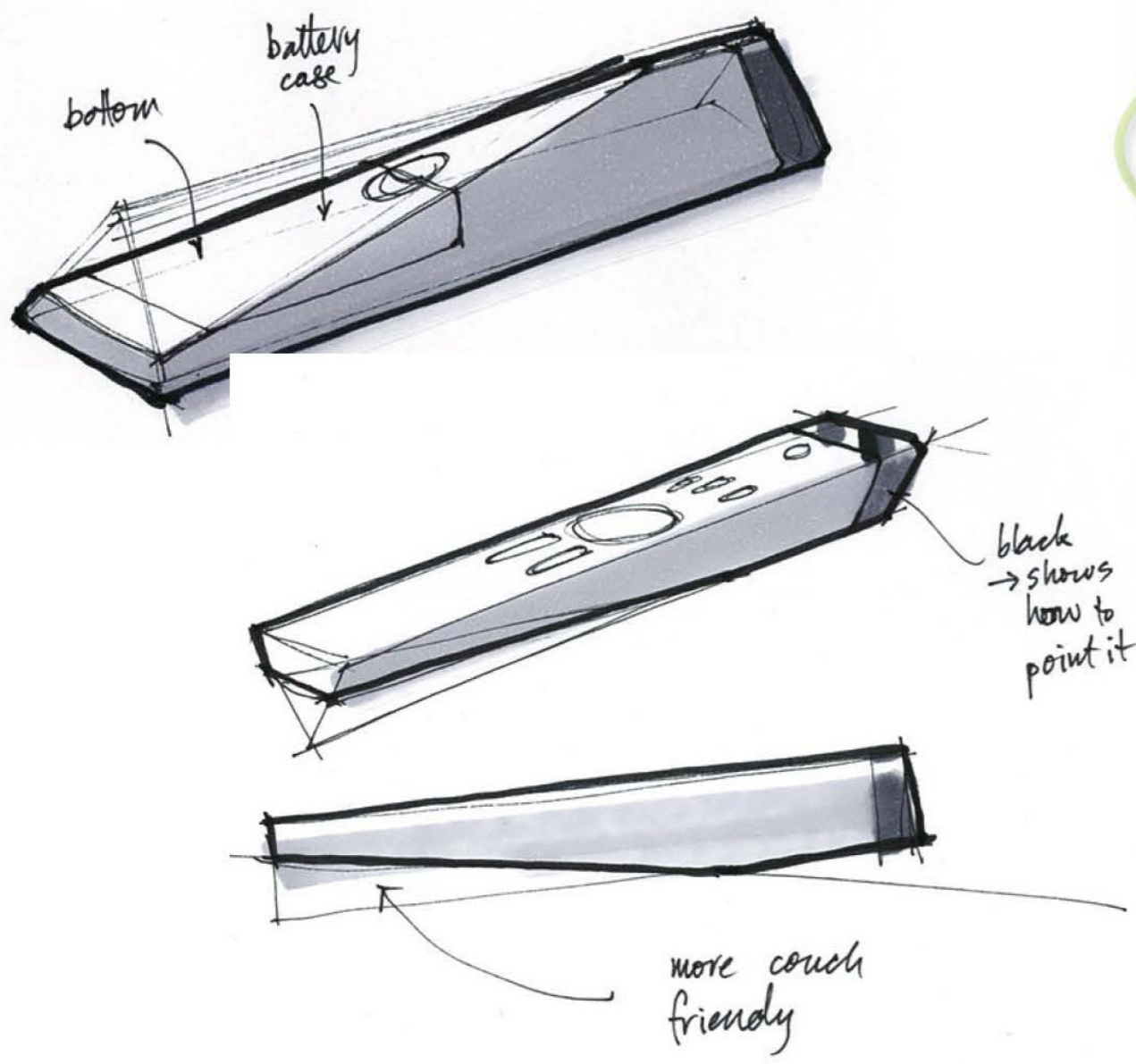
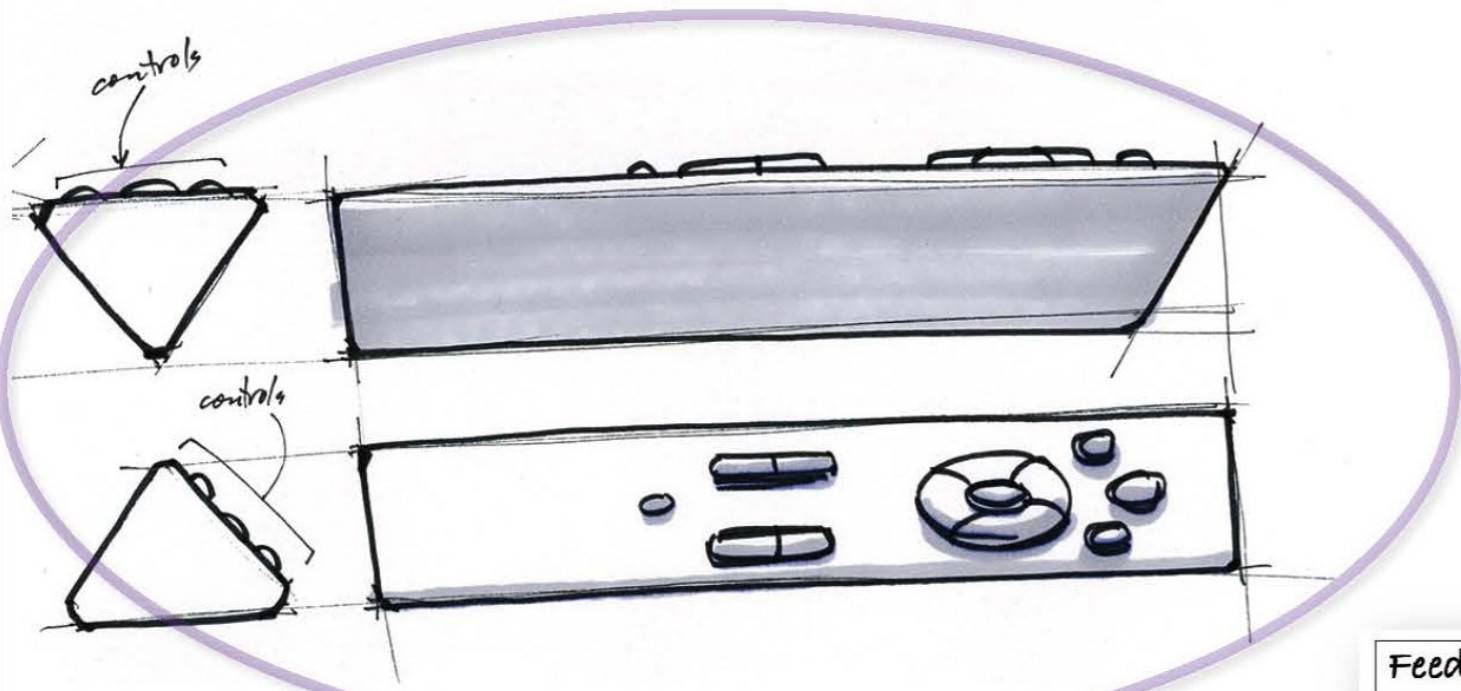

Feedback sheet: Remote Control 2. Meeting with Allen and Lilly

Design criteria	☹	☺	😊	😄	Attributes to be used in the design concept
Make the TV and DVD physically easy to use			✓		Needs a flat side so it sits facing up. Not enough information on the buttons.
Make the use of the TV and DVD easy to understand				✓	could the control layout from concept 1 be used? Might be easier to read. Colour? Feel?
Have a remote control that is easy to hold or use on the arm of a sofa or armchair				✓	Flat base is good on bottom drawing.
Be easy to install and setup, perhaps with the assistance of a more technical user?		✓			No information on this. Does it use the hidden set-up button like Concept 1?
Make the most common functions easy to access			✓		On/off button location is really clever.
Be elegant yet simple in its function				✓	Nice to have a different, distinct style of remote control.
Be compatible with the décor and interior design tastes of older people				✓	The shape is a good match for the style of the TV - both rectangular/angular.
Must not have highly technical features that are rarely used				✓	Looks simple enough to use easily. Not sure about set-up functions.
Must not be patronising to older people				✓	Simple, clean lines without looking simplistic. Works well.

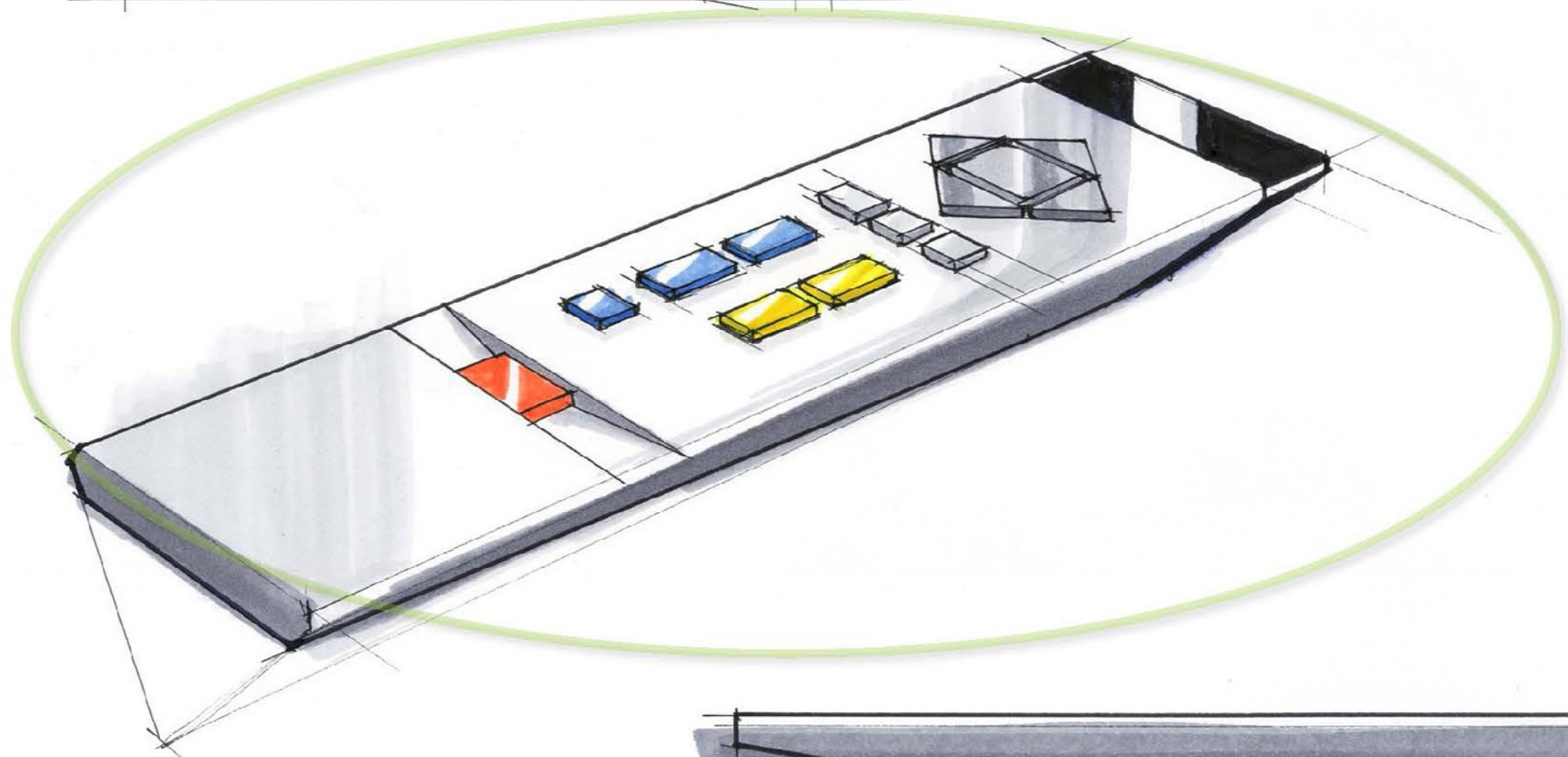
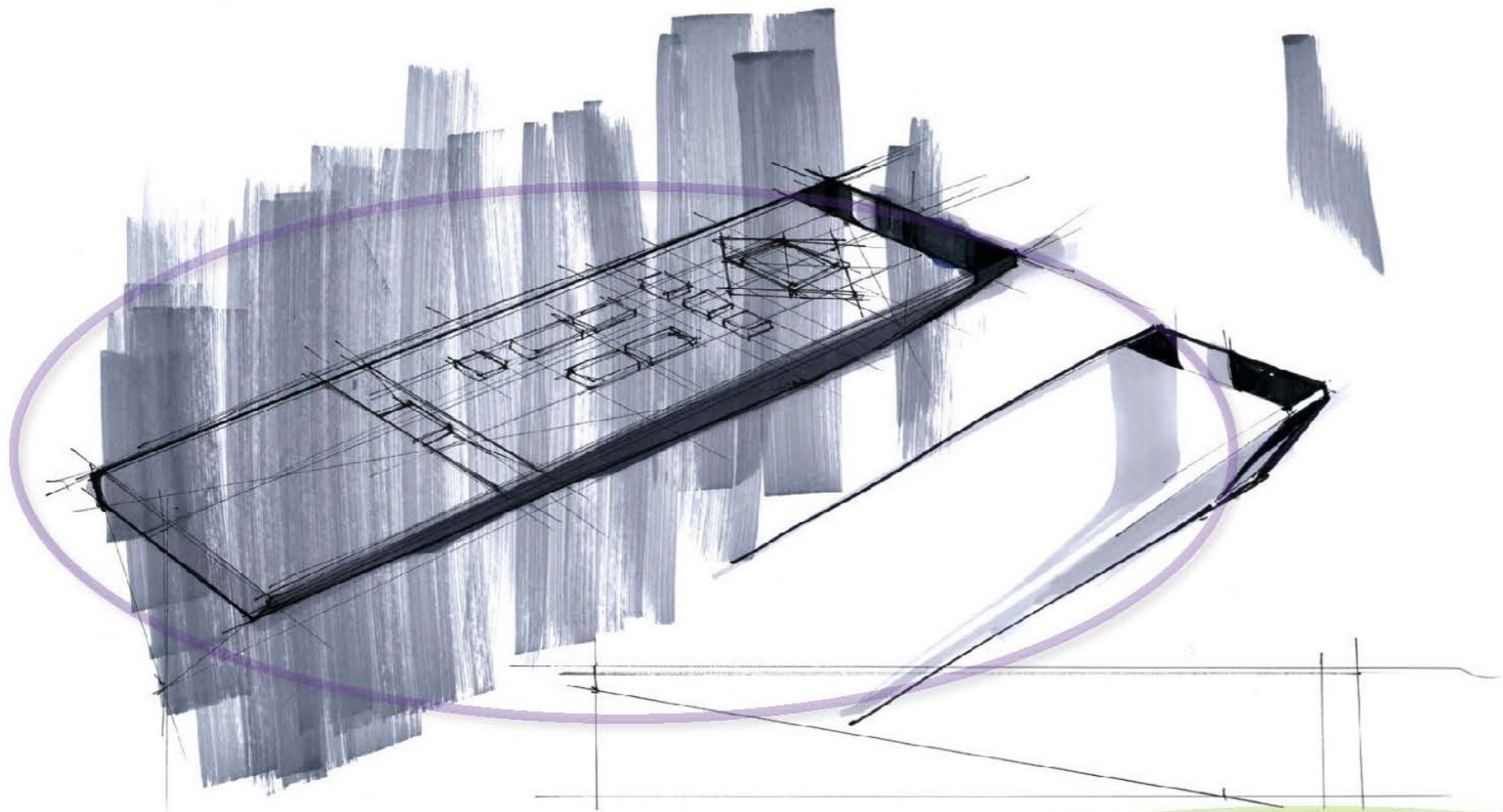

Part C

2-3 minute spoken supported by 2 x A3 sheets

Design Proposal

Easy TV

Integrated = Innovative
Timeless = Sustainable
Form = Aesthetic



Welcome, I'd like to talk about the Easy TV that I designed for my grandparents.

The strengths of my design and main innovations are that the DVD function is built into the front of the TV where it is easy to find. The remote control matches the square physical form of the TV so it is obvious that it is the TV remote and communicates its intended function. This also is likely to make the style of the remote and TV more timeless as the aesthetics relate to the function rather than a current trend in form or colour. The remote is not too large or too small for Allen and Lilly. They said it felt just right when they were holding it and liked the aesthetics of the shape. I've also designed it so that the buttons that you use most are in easy reach.

Easy TV

Simplified controls = Accessible
Easy to use = Useful

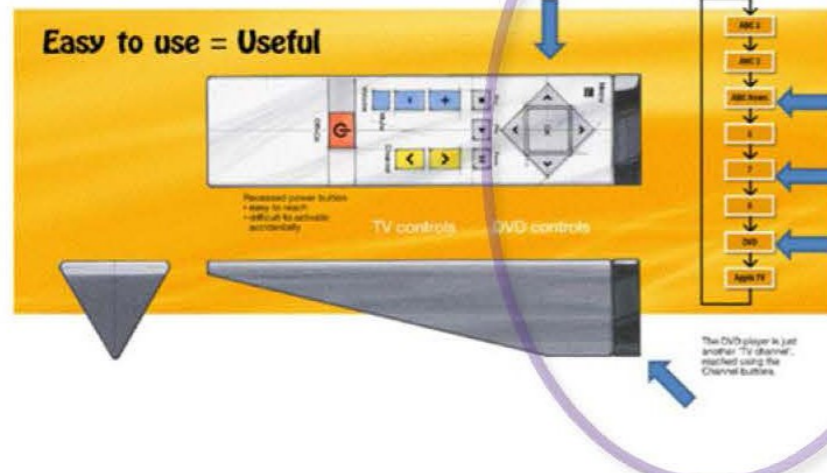

The volume and channel buttons are right under your thumb and I put the recessed power button right at the bottom where you can access it without moving your hand. I've put the LED transmitter in the front and made it like a shiny glass, which makes it accessible as it is easy to know which way to point it. These things make it suit older people without being patronising.

To make the use of the TV and DVD easier to understand for Allen and Lilly, I have simplified the controls to make them accessible. In the top half of the remote control, I put the essential DVD controls. I removed a whole lot of functions for the DVD that Allen and Lilly didn't use or know what they were for.

Allen and Lilly found the input button confusing as they said that when it was pressed the TV behaves differently. Instead I design my TV user interface to allow the user to get the DVD functions just by using the channel button. It's by simply going up and down scrolling through the list of TV stations that you eventually get to the DVD function.

Easy TV

Limitations
Implications

Suits older people
Elegant yet simple
Easy to use and understand



Thank you

The main limitations with my design is that by simplifying the TV, DVD and remote they may not fulfil their intended purpose for all older people. Allen and Lilly wanted an easy to use TV, but other older people might want the functions I have eliminated. This may also affect the sustainability of the design as less people would be likely to buy this TV second hand if it had less functions than other TVs.

An implication of my design is that by removing the controls that are to do with setting up there would have to be some other way to do the initial setup. Perhaps there could be a hidden button on the remote that a repair person could use that no one ever touches after the setup of the TV.

In summary, the Easy TV is perfect for older people wanting a combination TV and DVD that is easy to use and understand. So that's my design for the Easy TV and I hope you found it interesting.